

GALLAGHER TUMBLEWHEEL (G638) STRIP GRAZING INSTRUCTIONS

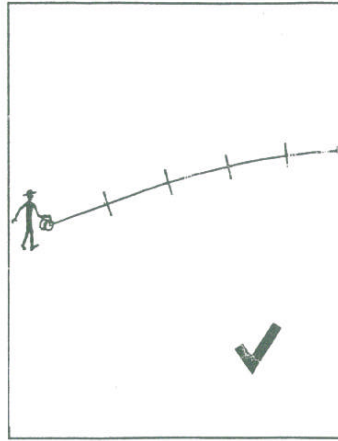

NOTE: Tumblewheels should never be dragged sideways, or damage may result.

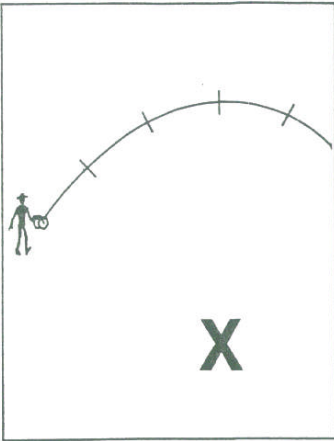
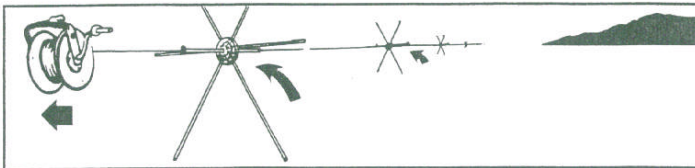

Fence wire must be pulled tight during initial installation on to wire and during fence moving - this guides the Tumblewheels in a direct line, otherwise they will move towards the centre of the fence.

DRAUGHTING OR SEPARATING STOCK

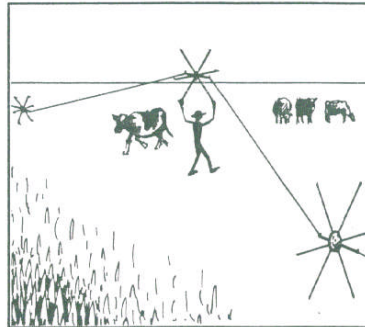
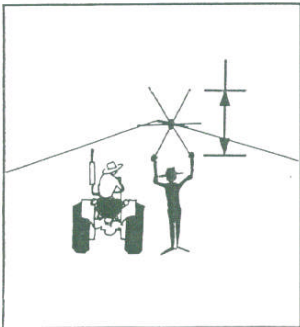

Lift Tumblewheels up *vertically* to allow stock and machinery to pass underneath wire.

A back fence means faster grass/animal feed recovery.

Reels at both ends make moving easier. Fences up to 200 (660') meters are easily managed from one end. 20 (66') meter spacing of Tumblewheels is practicable on level ground. Insulated plastic reels allow Tumblewheels to be moved with the power still on.

Tumblewheels will walk along even surfaced hillsides. When doing this, the lower end of the fence should be kept forward of the upper end, so that they "walk up" and counteract the tendency to move downwards. A Gallagher Joint Clamp (G603) can be used on the wire to stop sideways movement.

NOTE: Properly used and stored, Tumblewheels will be long lasting and an excellent management investment.

SQUARE Paddock OR FIELD

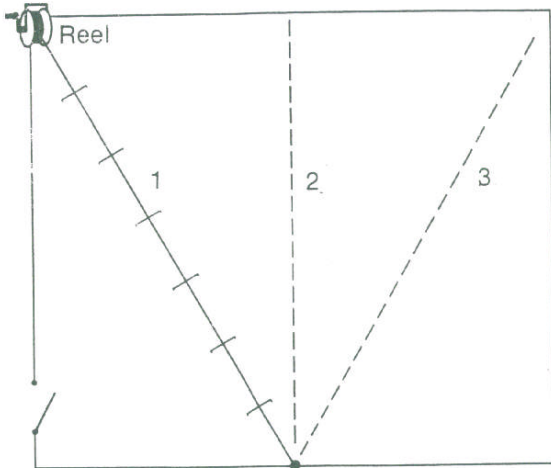

CENTRAL POST

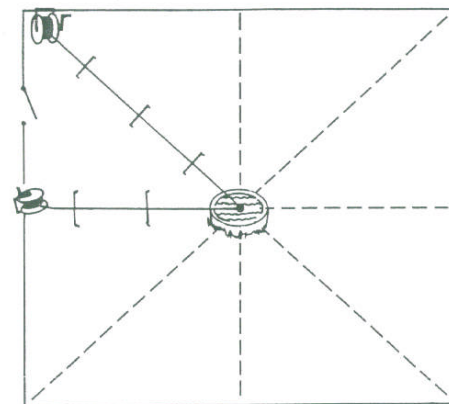

OBLONG Paddock OR FIELD

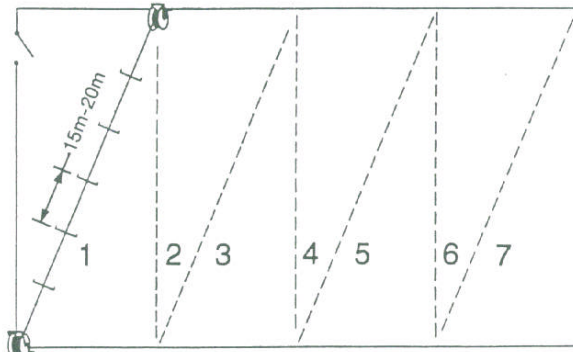

SIDE OF A HILL

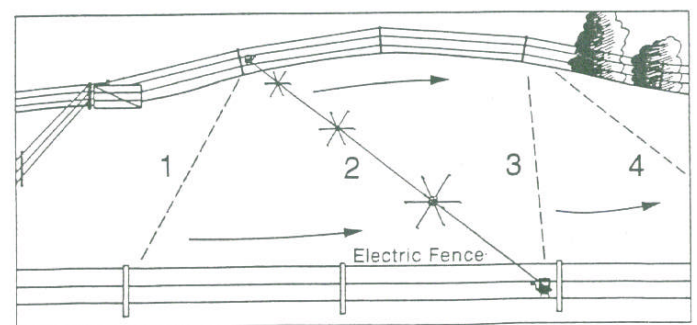

GALLAGHER ANIMAL MANAGEMENT SYSTEMS PRIVATE BAG 3026,
HAMILTON, NEW ZEALAND. EMAIL sales@gallagher.co.nz www.gallagher.co.nz

3E2337 - 04/10

GJ5734-3/93

GALLAGHER TUMBLEWHEEL_(G638) ASSEMBLY INSTRUCTIONS

